

Innovative H40-HP Profile Projector

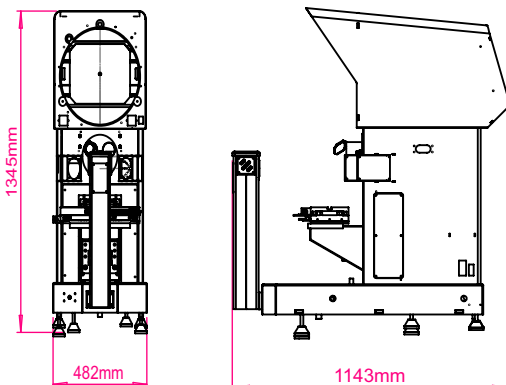

The **INNOVATIVE H400-HP** Profile Projector having screen diameter of 400mm combines high accuracy optical non-contact measurement & inspection with measuring range of 250mm x 150mm.

The horizontal light path arrangement is ideally suited for inspection of mechanical parts like shafts, thread gauges, metal cutting tools, etc; which can be secured to the work stage using wide range of optional accessories offered by Innovative.

FEATURES AND SPECIFICATIONS

- * 400mm (16") screen diameter, with 90 degree cross lines & chart clips.
- * Objective lenses from leading European companies.
- * Magnification accuracy of +/-0.05% on contour & +/-0.075% on surface.
- * Contour profile projection with fan cooled halogen lamp of 150W, 24V & amber filter.
- * Surface illumination with high intensity dual Halogen lamp of 150W, 24V.
- * Imported high precision LM cross rail guides for good repeatability & accuracy.
- * Hardened & ground work stage of size 407mm x 157mm & measuring stroke of 250mm x 150mm, with hard chrome plating.
- * Rapid movement on horizontal axis of work stage.
- * Focusing movement of 100mm (motorized with infinite speed control).
- * Maximum job weight inspection capacity of 15 Kgs.
- * Angular digital protractor of resolution 1' offered as standard.
- * Calibration from third party NABL accredited laboratory.
- * Available with range of simple DRO (X, Y & angle), LCD geometrical data processor & PC based geometrical data processor software's.
- * Linear Glass Scales of 0.001mm resolution are offered as standard with all DRO's & data processors.
- * Optical Edge detector is offered as standard with all data processors.
- * Innovative is the only Indian manufacturer, who does in house manufacturing of Profile Projectors, Linear Scales, Rotary Encoders, DRO's Geometrical Data Processors & Software's.
Thus it offers single point service support for profile projectors as well as its accessories.
- * Prompt & trained service support.

OPTIONAL ACCESSORIES

Digital Readouts and Data Processors

Simple X, Y, Ø DRO



OPP3X Geometric Data Processor



DP 200 Geometric Data Processor



DPS 200 Geometric Data Processor Software

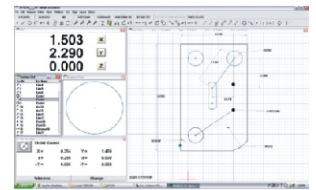

HOLDING FIXTURES

V Block & Center



Riser Blocks



Rotary Vice

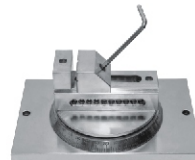

+91 2162 245 966
246 509
+91 2162 248 012

HO & Factory : B/24, M.I.D.C., Industrial Estate, Satara - 415 004. Maharashtra. INDIA

sales@innovatedro.com www.innovatedro.com

Sales Office : B-5, Golden Orchid, Sector 11, Plot No. 136, New Pradhikaran-Chikhali Road, Bhosari, Pune - 411 019. Maharashtra. INDIA +91 20 6510 2543 / 6510 2593